

ESSENTIAL DATA DUPLICATOR III™

EDD is the most powerful copy program available for backing up your protected Apple software.

Unlike the copycards, which only copy single load programs, **EDD** backs up entire disks. Thus, not only copying single load, but, multi disk access programs as well.

Since **EDD** has been preset to copy a broad range of copy-protections, many disks can be copied easily, without changing messy parameters. Even though you rarely need to change parameters, each parameter is fully described in this manual.

EDD is very fast. Average duplication time is less than 2½ minutes. **EDD** automatically finds "self sync" bytes and their lengths. **EDD** can copy not only whole and half tracks, but quarter and three quarter tracks as well.

The current **EDD** programs list, a list which contains special instructions (if needed) for backing up commercially available protected software packages, is enclosed. Registered **EDD** owners are eligible to receive updated lists when published (published four to six times a year).

Our saying is, "Novice users using **EDD** can back up more protected disks than many experienced users can back up using other copy programs or copycards".

EDD runs on Apple II, II plus (including most compatibles), IIe, and III (in emulation mode), with one or two 3.3 disk drives. Essential Data Duplicator III was written by Donald Anthony Schnapp.

UTILICO SOFTWARE

83 Hall St. Bondi Beach
N.S.W. 2026
Australia
Phone (02) 30 2105

13438

Essential Data Duplicator III™



BACK UP
YOUR DISKS



UTILICO MICROWARE

Scanned by cvxmelody

<http://www.cvxmelody.net/AppleUsersGroupSydneyAppleIIDiskCollection.htm>

NOTICE:

UTILICO MICROWARE reserves the right to make changes or improvements in the software described in this manual or in the manual itself at any time without notice.

DISCLAIMER:

13438

UTILICO MICROWARE makes no warranties, either implied or expressed, with respect to this manual or the software described in this manual, its quality, its performance, or its marketability. UTILICO MICROWARE programs and manuals are sold "as is". The entire risk as to the quality and performance of the program and/or manual is borne by the buyer. Should the program and/or manual prove defective following its purchase the "buyer", assumes the entire cost of all necessary servicing, repair, or corrections and/or any incidental or consequential damages. In no event will UTILICO MICROWARE be liable for direct, indirect, incidental, or consequential damages resulting from any defect in the software and/or manual. Some states do not allow the exclusion or limitation of implied warranties or liability for incidental or consequential damages, so the above limitation or exclusion may not apply.

Your ESSENTIAL DATA DUPLICATOR III has been recorded on both sides of the disk for your convenience. Each side has been tested (booted) prior to shipment on an Apple computer system with an Apple disk drive. If your ESSENTIAL DATA DUPLICATOR III disk should ever fail to boot, send it back to us with a copy of your receipt together with a check or money order for \$2.00 to cover the cost of shipping and handling. We will rewrite the same disk and return it to you. If the disk is physically damaged and has to be replaced, please enclose \$5.00 for disk replacement, shipping, and handling.

Technical phone support is available weekday mornings only, pacific time.

UTILICO MICROWARE
3377 Solano Ave., Suite 352
Napa, CA. 94558
(707) 257-2420

ESSENTIAL DATA DUPLICATOR III was written by Donald Anthony Schnapp.

COPYRIGHT (C) 1984 UTILICO MICROWARE
ALL RIGHTS RESERVED.

Apple is a trademark of the Apple Computer Corporation.

ESSENTIAL DATA DUPLICATOR MANUAL

Table of Contents

DISCLAIMER.....Inside Front Cover

INTRODUCTION.....1

RUNNING EDD.....3
The Option Menu

SHORT COURSE.....5

BASIC OVERVIEW7

OPTION 1 DUPLICATE A DISK.....10

OPTION 2 CHANGE PARAMETERS.....15
Brief Description
Detailed Description

OPTION 3 ANALYZE ORIGINAL DISK.....24

OPTION 4 EXAMINE SPEED OF ORIGINAL DISK.....28
Overview
Speed Charts
Adjust Drive Speed To Disk

OPTION 5 CHECK DRIVE SPEED.....33
Adjust Drive speed

OPTION 6 CHANGE SLOTS & DRIVES.....35

OPTION 7 CLEAR ERROR STATUS.....35

OPTION 8 QUIT, BOOT DISK.....35

APPENDIX A; Removing Drive Cover.....36
Replace Drive Cover

APPENDIX B; Numbering Disk Drives.....37
Using Numbered Tracks

APPENDIX C; Copy-Protection Schemes.....40
Common protections
Advanced protections

APPENDIX D; Hex/Decimal Conversion.....42

APPENDIX E; Common Errors.....43

APPENDIX F; General Information.....45

TRICKS OF THE TRADE.....46
Recommended reading

INTRODUCTION

Just about every commercial software package that you purchase for your Apple computer is copy-protected. This is not to be confused with copyrighted. Copy-protected means that a disk containing a computer program is electronically protected so that you could not make a working copy of it. The main purpose of copy-protections is to keep dishonest people from illegally making and selling copies of someone else's computer programs. The only problem is that an honest person who needs (and legally is entitled to) legitimate back up copies would not be able to make them. One way around this problem is to buy two of everything. The other way, is to copy them with EDD.

In February 1983, Essential Data Duplicator, EDD version one was released, although this copy program had very few options, it was able to copy many of the tougher protections. After obtaining feed back from EDD users, many routines were added and several routines were rewritten. EDD version two was released in June 1983. Although this version was still regarded as "the best copy program in town", we decided to release an even more powerful, more accurate, and faster copy program. Here it is, EDD version III.

Nowadays, most protected computer programs are becoming disk-based, which means that the disk may contain several parts of the protected program. When the program is ran, only one part of it is actually in the computer at a time while the other parts are available on the disk. This means that the only reasonable way of duplicating the protected program is to duplicate the entire disk.

EDD has been designed to be used by a wide range of Apple users: From beginners to the experts, from business people to the hobbyist.

EDD runs on a standard 48k Apple II, II plus, IIe, or III (in emulation mode) with a DOS 3.3 controller card and one disk drive, although two disk drives are recommended for smoother and faster operation.

EDD duplicates disks accurately and quickly. EDD can check the speed of your disk drives to see if they are running at the standard speed of 300rpm and allows you to adjust the speed of your disk drives to that standard speed. While you are backing up your disks, you can adjust your drive speeds to the speed at which your original disk was written for a more accurate copy. EDD can also analyze your disks, to help you find the tracks that contain valid data.

Although EDD's duplication options have been preset to copy most disks (so you would not usually need to change anything), you can easily change the slot(s), drive(s), and/or which tracks to be copied. You can also choose which duplicating process to use. With a little knowledge of disk drives and copy protections, you can customize EDD to duplicate almost any Apple disk.

After owning and testing the other copy programs and copycards, we feel that an average user can copy between 5 to 20% (depending on the copy program or copycard) of his copy-protected software. After testing EDD, we feel that an average user should be able to copy around 90% of his same protected software, most without changing any parameters.

From time to time we publish an EDD PROGRAMS LIST. This is a list of protected programs that EDD has been known to copy. If certain protected programs need parameter changing, this information would also be included in the list. This list is available only to registered EDD owners. If you would like to receive a current list, please send us a self addressed stamped envelope. Remember to always include your registered serial number.

If you would send us the names of any programs which you can back up, using EDD, together with any parameters used, we will see that they are included in the next edition of the EDD PROGRAMS LIST. In this way other EDD users may benefit from your experience.

WARNING: Almost every software package available on the market has a serial number. You may not physically be able to see the serial numbers, but they are often encoded several times through out the program. Many dealers are required to keep records of these serial numbers and the people who purchase them. Records are kept regardless if you send in the registration card or not. When a software company obtains an illegal copy of their own program, they can easily track down the owner and prosecute. EDD is exclusively sold only for the sole purpose of backing up your own software for yourself.

GETTING ESSENTIAL DATA DUPLICATOR UP AND RUNNING:

Note: If you are using an Apple III computer, be sure to boot your emulations disk first. Then insert and boot the EDD disk.

Make sure that the Essential Data Duplicator, EDD disk is write-protected (no notch showing). Insert the EDD disk into the #1 main disk drive, and close the drive door.

Turn the computer on.

After about five seconds, a hi-resolution graphic picture will appear and EDD will be loaded. You should hear a beep, and the disk drive will stop. EDD is now completely loaded. Take the EDD disk out of the disk drive, placing it back into its protective envelope.

Pressing any key will display our company's name/address, pressing another key will put EDD at the OPTION MENU:

```
--- ESSENTIAL DATA DUPLICATOR ---  
000000000000000011111111111111112222  
TRK:0123456789ABCDEF0123456789ABCDEF0123  
.00(  
.25(  
.50(  
.75(  
ORIGINAL:S=6,D=2  DUPLICATE:S=6,D=1
```

- OPTION MENU -

1. DUPLICATE A DISK.
2. CHANGE PARAMETERS.
3. ANALYZE ORIGINAL DISK.
4. EXAMINE SPEED OF ORIGINAL DISK.
5. CHECK SPEED OF DISK DRIVES.
6. CHANGE SLOTS/DRIVES.
7. CLEAR ERROR/PROCESS CODES.
8. QUIT, BOOT DISK.

1

EDD is now up and running.

If an error occurs while EDD is being loaded, a screen full of dots will be displayed and EDD will reboot.

IF EDD DOES NOT LOAD OR WORK PROPERLY, CHECK FOR THE FOLLOWING:

Be sure you are using your original EDD disk.

Not enough memory. You must have at least 48k of RAM memory.

Possibly defective RAM or ROM memory.

Disk speeds may either be very slow or very fast.

EDD has to be write-protected before it will boot. Maybe the write-protect switch located inside of your disk drive is out of adjustment.

EDD has been recorded on both sides of the disk. Try booting the other side.

SHORT COURSE FOR DUPLICATING DISKS:

These basic steps are often all you need to know to copy most disks:

After booting EDD and the OPTION MENU is displayed, you must first decide how many disk drives you are going to use. Located just above the center of your screen, the slots/drives are posted. EDD has been preset for the use of two disk drives:

```
ORIGINAL:S=6,D=2  DUPLICATE:S=6,D=1
```

```
Original disk; slot=6, drive=2.  
Duplicate disk; slot=6, drive=1.
```

Note: This is just the opposite of most other copy programs.

*** If you are using only one disk drive (probably in slot 6, drive 1) or your disks are in different disk drives, you will need to tell EDD the position of the drives you want to use. If this is the case, you will need to use OPTION 6 (press "6" and answer each question with the correct value).

From the OPTION MENU, keeping the default "1", press RETURN.

The bottom of the screen will display:

```
START TRACK=00  
END TRACK=22  
INC TRACK=01
```

```
PROCESS MODE#1
```

1. NORMAL
2. SYNCHRONIZE TRACKS
3. AUTO NIBBLE COUNT
4. MANUAL NIBBLE COUNT
5. SYNC TRACKS AND AUTO COUNT
6. SYNC TRACKS AND MANUAL COUNT
7. ERASE TRACKS ONLY

You will be asked just four questions:

```
START TRACK=00      press RETURN  
END TRACK=22       press RETURN  
INC TRACK=01       press RETURN  
then,  
PROCESS MODE#1     press RETURN
```

EDD is now telling you to insert both, the original and duplicate disk (if you are using only one disk drive, EDD tells you to insert the original disk).

*** Before attempting to copy any disk, be sure the original disk is write-protected and the duplicate disk is not. If the disks aren't, EDD will display an error message. Write-protect instructions are explained in your Apple DOS 3.3

manual on pages 36-37.

Press any key to start the duplication process.

If you are using just one disk drive, you will need to exchange the original disk and the duplicate disk several times until the duplication process is finished... EDD will prompt you when to insert which disk.

When EDD is finished, a DONE message will appear on the screen.

A BRIEF SUMMARY FOR DUPLICATING DISKS:

Be sure the slots/drives are correctly set (use OPTION 6 if needed).

From the OPTIONS MENU:

```
Press RETURN  
Press RETURN  
Press RETURN  
Press RETURN
```

Make sure the original disk is write-protected and the duplicate disk is not.

Insert disks into their correct drives.

Press RETURN.

If you are using only one drive, EDD will prompt you when to exchange the original and the duplicate disks.

When EDD is finished, a DONE message will appear.

BASIC OVERVIEW:

COMPUTER COMPATIBILITY:

If you are using an Apple IIe, be sure that the CAPS LOCK key is down.

If you are using an Apple III, be sure to boot your emulations disk before booting EDD. After you are done making back up copies of your Apple III software, turn the computer OFF before trying to use them. Remember, the computer is configured to an Apple II while in the emulation mode.

DRIVE SPEED:

It is very important when you are backing up your disks, the ORIGINAL disk is in the faster disk drive and the DUPLICATE disk is in the slower disk drive. Use OPTION 5 for checking the speed of your disk drives. If the speeds are running too fast or slow, they will first need to be adjusted (see OPTION 5).

ABBREVIATIONS:

In this manual, when ever you see the abbreviation "mode#" we are referring to which PROCESS MODE# to use (see OPTION 1). When ever you see the abbreviation "parm" we are referring to a parameter (see OPTION 2).

WRITE-PROTECT ORIGINAL DISK:

Before EDD will process any of your ORIGINAL disks, your ORIGINAL disks must be write-protected. If they aren't, EDD will stop, displaying an error message. This is for your protection. See your Apple II DOS manual pages 36-37 if needed.

SPECIAL KEYS:

When you are told to "PRESS ANY KEY", while using EDD, we are referring to the RETURN key, the SPACE BAR, or any of the alpha/numeric character keys.

"ESC" key: While you are running EDD; pressing ESC will stop whatever you are doing, and restart you at the OPTION MENU. If you press ESC while EDD is involved with a major routine, the computer may take a couple of seconds to respond.

"SPACE BAR" key: While you are duplicating disks (OPTION 1) with two disk drives, analyzing an original disk (OPTION 3), or examining the speed of an original disk (OPTION 4), pressing the SPACE BAR will temporarily halt the computer. Press any other key to continue processing.

"Cntrl-S" key: Pressing cntrl-S from any prompt will disable all sound routines.

"-" key: While duplicating disks with two disk drives,

pressing the "-" key will prevent EDD from fixing write errors (W or L) if they occur. This way, if you know that certain tracks are going to give errors, you can speed up processing. Pressing a different key will resume processing as normal. To use this feature while duplicating disks with a single disk drive; press the "-" key each time EDD tells you insert the DUPLICATE disk.

ERROR / PROCESSING CODES:

While using the different options of EDD, the top of the screen will display processing codes followed by error codes.

Displayed in INVERSE video, the processing codes are as follows:

R = READING track from original disk (Option 1).
P = PROCESSING track (Option 1).
W = WRITING track to duplicate disk (Option 1).
V = VERIFYING the written track (Option 1).
E = ERASING track on duplicate disk (Option 1, mode#7).
A = ANALYZE original disk (Option 3).
S = Examine SPEED of original disk (Option 4).

If used, the following will be displayed in FLASH video:

S = SYNCHRONIZING track (Option 1, mode#2).
G = Cleaning timing GAPS (Option 1).
A = ANALYZING or modifying track (Option 1).

Displayed in NORMAL video, the error codes with comments and possible problems are as follows:

. = Track is copied correctly (Option 1).
No errors were encountered.
Track appears to contain large amounts of valid data (option 3).
Track appears to have a strong signal.
R = READ error occurred on the original disk (Option 1).
Track would not verify against itself.
Track length could not be found.
Couldn't find the same place on track twice.
Timing gap too small.
Track contains invalid data.
Unrecorded or erased track.
C = Track had to be COMPRESSED (Option 1).
Copy still has a good chance of working.
Duplicate drive speed too fast.
Original drive speed too slow.
Possible read error.
Possible write error.
L = Track LENGTH is too long (Option 1).
End of track over-wrote start of track.
Duplicate drive speed too fast.
Possible read error.
Possible write error.

W = WRITE error occurred on duplicate disk (Option 1).
 Written track would not verify.
 Written track length could not be found.
 Track may be unrecorded or erased.
 Track contains invalid data.
 Duplicate drive speed too fast.

S = SYNCHRONIZE track error (Option 1, mode#2).
 Track was not synchronized correctly.
 Usually only happens when parm 00 is changed.

- = Track appears to be only partially recorded (Option 3).
 Cross talk (bleed over) from an adjacent track.
 Track has a weak signal.
 Track contains invalid data.

* = Duplicate track has been erased (Option 1, mode#7).
 Track appears to contain little or no valid data (Option 3).
 Track is unrecorded.
 Cross talk from an adjacent track.
 Track has a very weak signal.
 Track contains invalid data.

DEFAULT VALUES:

Often when you are prompted for an entry, the computer will display a possible "default value" to use. You can accept this value by just pressing RETURN, or you can override this default by typing in your own value.

NUMBERING SYSTEM:

All values used by EDD are in Hexadecimal notation (see Appendix D for chart).

1/4 AND 3/4 TRACKS:

EDD can access not only whole and half tracks but 1/4 and 3/4 tracks as well. When EDD asks you for a track number and you want to enter a 1/4 track press ".2" (for .25). To enter a 3/4 track press ".7" (for .75). Although just about every Apple disk drives can access 1/4 and 3/4 tracks, we have found some (very few) that can't. The best way of telling, is to number your disk drives (see Appendix B), then use OPTION 3 (Analyze Drive Speed), specifying track 21.75. Watch the arm move gear. If the head actually moves to track 21.75, then your disk drive is probably working correctly.

OPTION 1: DUPLICATE A DISK.

After pressing RETURN (default "1") from the OPTION MENU, the monitor will display:

```

-- ESSENTIAL DATA DUPLICATOR --
0000000000000001111111111111112222
TRK:0123456789ABCDEF0123456789ABCDEF0123
.00(
.25(
.50(
.75(
ORIGINAL:S=6,D=2  DUPLICATE:S=6,D=1

START TRACK=00
END TRACK=22
INC TRACK=01

```

PROCESS MODE#1

1. NORMAL
2. SYNCHRONIZE TRACKS
3. AUTO NIBBLE COUNT
4. MANUAL NIBBLE COUNT
5. SYNC TRACKS AND AUTO COUNT
6. SYNC TRACKS AND MANUAL COUNT
7. ERASE TRACKS ONLY

You are prompted to select the START TRACK (the track from which EDD will start processing). Default=00. Press RETURN or type in your own track number between 00 and 23.75. Enter the track number in two parts; the part to the left of the decimal is in hexadecimal notation. The part to the right can be only one of four numbers designating the appropriate quarter track to access as follows:

Whole number track	.00	(entry of .00 is optional)
One-quarter track:	.25	(press .2)
Half-track	.50	(press .5)
Three-quarter track	.75	(press .7)

After making your start track selection, you are prompted to select the END TRACK (the track where EDD will stop processing), default=22. Either press RETURN or enter your own value and then press RETURN.

You are now prompted to enter the INC TRACK (the track increment or step value). This may be as small as quarter track increments but is not usually less than one whole track, which is the default value. Apple disk drives are not precise enough to write closer without data bleeding over and erasing adjacent tracks. The value you select will be used to move the read/write head to the next track position and will increase the track number by this amount for each track move. The track number will continue to increase by this amount until it exceeds the value selected for the END TRACK value. Press RETURN or type in your own increment value and then press RETURN.

Next, EDD is asking you which PROCESS MODE (mode#) you want to use:

1. NORMAL (the default) copies one track at a time from the original disk to the duplicate. This may take as little as 2 1/2 minutes with two disk drives for many copy-protections. EDD will attempt to copy each track in turn, transferring the data bytes and the timing bits from the original disk onto the duplicate. If the length of a duplicate track is shorter than the original track (usually meaning that the duplicate disk drive is running too fast), EDD will automatically compress the track (erase some of the timing bits) until it fits onto duplicate disk, displaying an error code "C". If most of the timing bits are erased and the track still doesn't fit, an error code "L" will be displayed. If either of these error codes are displayed, You will probably have to slow down the duplicate disk drive if you want to copy this track more accurately.

2. SYNCHRONIZE TRACKS uses the same copy routine as NORMAL, but also synchronizes each track in relationship to each other. Note; when synchronizing tracks, be sure to copy track "0" first. This is done when 00 is selected for the START TRACK. Drive speed may be critical.

3. AUTO NIBBLE COUNT uses the same copy routine as NORMAL, but also tries automatically to make the length of the duplicate track the same length as the original either by erasing or inserting timing bits. Because EDD has to erase or insert timing bits, this is an easy but less accurate way of preserving track lengths.

4. MANUAL NIBBLE COUNT is similar to AUTO LENGTHS. Although, this mode is much more accurate. You will have to physically take the cover off of the duplicate's disk drive (see Appendix A) and manually adjust the drive speed (see OPTION 5 for locating speed adjustment screw) until the DIFFERENCE in track length (displayed in the lower-right corner of the screen) shows 0000. Turning the speed adjustment screw clockwise will speed up the drive, turning the screw counter-clockwise will slow down the drive. This mode does not insert or erase timing bits.

5. SYNC TRACKS AND AUTO COUNT uses both the SYNCHRONIZE TRACKS and the AUTO NIBBLE COUNT routines together.

6. SYNC TRACKS AND MANUAL COUNT uses both the SYNCHRONIZE TRACKS and the MANUAL NIBBLE COUNT routines together.

7. ERASE TRACKS ONLY. EDD will erase the tracks specified on the duplicate disk. EDD doesn't read from the original disk.

Choose the PROCESS MODE (mode#) you want by selecting a number, 1-7, or pressing RETURN keeps the default "1" (When attempting to duplicate an Apple II disk for the first time, "1" should always be your first choice). If you are backing up Apple III software, use mode#2.

Before you load the disk drives with the correct disks (displayed below the error/processing codes on the screen), make sure the original disk is write-protected and the duplicate disk is not (if they aren't, EDD will stop, displaying an error message).

*** Note: If you are using only one disk drive, EDD will prompt you when you need to exchange disks.

Press the RETURN key to start the duplication process.

*** Note: When copying disks using two disk drives; pressing the SPACE BAR during the duplication process will manually single step EDD through each track, displaying a "PAUSING" message after that track is processed. Pressing the RETURN key will allow EDD to continue processing automatically.

By watching the error/processing code status display at the top of screen, you will be able to see which process EDD is performing and any errors which may occur.

Displayed in INVERSE video, the processing codes for this option are as follows:

R = READING track from original disk.
P = PROCESSING track.
W = WRITING track to duplicate disk.
V = VERIFYING the written track.
E = ERASING track on duplicate disk (mode#7).

If used, the following will be displayed in FLASH video:

S = SYNCHRONIZING track (mode#2).
G = Cleaning timing GAPS (if parm 5 is greater than 0).
A = ANALYZING or modifying track (if parm 28 is greater than 0).

Displayed in NORMAL video, the error codes with comments and possible problems are as follows:

. = Track is copied correctly.
No errors were encountered.
R = READ error occurred on the original disk.
Track would not verify against itself.
Track length could not be found.
Couldn't find the same place on track twice.
Timing gap too small.
Track contains invalid data.
Unrecorded or erased track.
C = Track had to be COMPRESSED.
Copy still has a good chance of working.
Duplicate drive speed too fast.
Original drive speed too slow.
Possible read error.
Possible write error.
L = Track LENGTH is too long.
End of track over-wrote start of track.

Duplicate drive speed too fast.
Possible read error.
Possible write error.

- W = WRITE error occurred on duplicate disk.
Written track would not verify.
Written track length could not be found.
Track may be unrecorded or erased.
Track contains invalid data.
Duplicate drive speed too fast.
- S = SYNCHRONIZE track error (mode#2).
Track was not synchronized correctly.
Usually only happens when parm 00 is changed.
- * = Duplicate track has been erased (mode#7).

When EDD is finished duplicating a disk, you will hear a beep, and a DONE message will be displayed on the bottom of the screen. Press any key to return to the OPTION MENU.

Stated simply, EDD reads a track from an original disk and then writes the track to a duplicate disk. While this is happening, EDD attempts to check and verify for errors. Since there are so many different ways of protecting a disk, there is almost no way of being positively sure that the duplicate disk actually works until you try to run it, even if the processing codes for a disk give all dots (copied correctly). On the other hand, the screen may display all kinds of nasty error codes while duplicating a disk, but the duplicate disk may still work perfectly. You won't know until you run it.

While EDD is duplicating a disk, a number of fields of data will be displayed on the screen (see Figure 1); TRACK END/START raw data and timing bits, largest timing GAP LENGTH, TRACK LENGTH, and DIFFERENCE in track lengths between original disk and duplicate disk. If synchronizing tracks (mode#2), the SYNC TIMER will also be displayed.

TRACK END/START: When your disk drive looks at a disk, each track appears to be a circular stream of bytes. EDD reads the track several times to be sure that there is at least one whole good track sample in memory. EDD then displays the track's end and start on the screen. If you are experienced enough, you may be able to tell by inspection if this is correct or not. Parameters can be changed, if necessary, to calculate (or define) a different track start. The timing bits on the left are the amount of extra bits written before the corresponding raw data byte on the right are written.

LARGEST GAP LENGTH: This data shows the length of the largest timing gap found in that track.

LENGTH OF TRACK: This data shows the length of the original track.

DIFFERENCE in track lengths between the original disk and the duplicate disk: After the track is written to the duplicate disk, it is read back into memory. The length of the duplicate track is found and compared against the original track length. The difference between the track length is

displayed on the screen. If the duplicate track is longer than the original track, the value will be displayed with a greater-than sign. If the duplicate track is shorter than the original track, the value will be displayed with a less-than sign. If the less-than sign is displayed while you are using the NORMAL processing mode (mode#1), EDD will automatically attempt to compress the track giving an error code "C". A long track is often better than a short track.

Example:

DIFFERENCE: (0023 = The duplicate track is shorter than the original track by 23 bytes of data. (the duplicate disk drive is probably running too slow.)

DIFFERENCE:)001A = The duplicate track is 1A bytes longer than the original track. (almost always O.K.)

SYNC TIMER (if used): When synchronized tracks are written (using mode#2), a special method of positioning the track is used. It involves selecting a known starting point on a certain track (usually track "0") and using it as a jumping-off point for the arm move to the new track, then wasting some time (measured in cycles), until the point is reached where the writing is to begin for this new track. Usually, the smaller the delay, the more accurately the synchronized track will be written.

Figure 1 is a typical screen display while making a back up copy of a disk. This sample is from a copy-protection that is similar to a DOS 3.3 format:

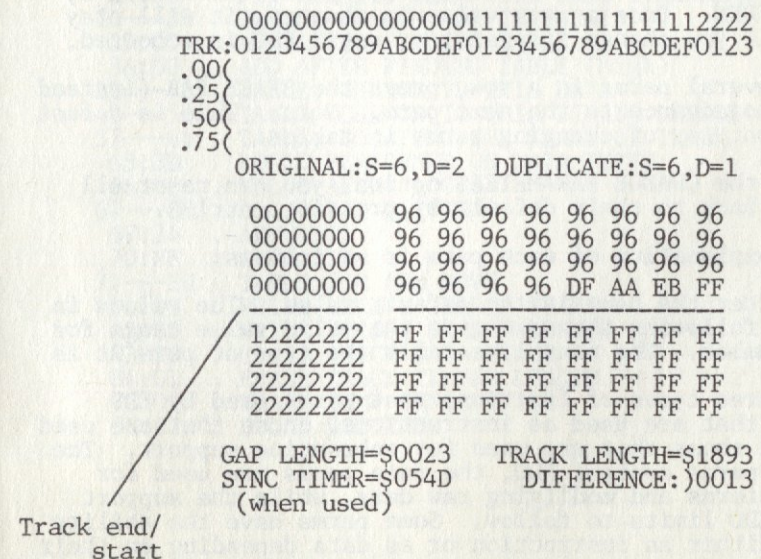

Figure 1

OPTION 2: CHANGE PARAMETERS.

The CHANGE PARAMETERS option allows you to modify EDD and copy certain protected disks that you could not copy otherwise. The default parameters have been preset so that most protected disks can be duplicated without any parameter changes. So, on your first attempt at duplicating a disk, you should copy the disk using only the NORMAL mode with the preset parameter values.

This option has been designed for the more advanced user. The more knowledge you have about disk drives and copy-protections, the better you will be able to determine which parameters may need to be modified for certain types of copy-protections.

From here through the rest of this option, instead of using the word "parameter", we will be using the word "parm".

On the opposite page is a brief listing of all the parms used by EDD. The number on the left side of the colon is the actual parm number. The number on the right side of the colon is the default parm value. On the right side of the period is the parm name or function.

Lets say that you want to change parm number "28" to the value "3". From the OPTION MENU press 2, CHANGE PARAMETERS. EDD is asking you which parm number you want to change. type in the number 28 then press RETURN. EDD will display the value this parm currently is set at. To change it, press the number 3, and then RETURN. Once a parm value is changed, it will stay changed until you change it again, or until EDD is rebooted.

To change several parms in a row, press the SPACE BAR (instead of RETURN) to advance to the next parm. Note: This is a fast and convenient way of changing parms in tables.

While using the CHANGE PARAMETERS option, you can reset all parm values back to their default by pressing cntrl-R.

A detailed explanation of each parm is as follows:

The value after the name is the default value. The values in parenthesis following the name give the valid value range for that parm number. The next line tells the type of parm it is.

There are three types of functions that parms used by EDD have; those that are used as instructions, those that are used as data, and those that are used for subroutine support. The instruction parms control EDD, the data parms are used for locating patterns and modifying raw data, while the support parms give EDD limits to follow. Some parms have the ability to be used either as instruction or as data depending on their value.

00. OVERRIDE ERRORS:00. (00-04)

Instruction parm. Used with errors and to direct processing. Each bit position is used as follows:

0:00	. OVERRIDE ERRORS
1:00	. LEAD-IN DATA VALUE
2:02	. LEAD-IN DATA EXTRA BITS
3:05	. MAXIMUM WRITE ERRORS ALLOWED
4:03	. MAXIMUM READ ERRORS ALLOWED
5:18	. TIMING GAP CLEAN ROUTINE
6:00	. TRACK GAP ROUTINE
7:00	. CUT GAP POSITION
8:FF	. ADD GAP
9:FF	. ADD GAP (high)
A:1A	. MAXIMUM TRACK LENGTH
B:13	. MINIMUM TRACK LENGTH
C:11	. KNOWN DATA LENGTH (high)
D:08	. COMPRESS START
E:70	. COMPRESS OFFSET
F:10	. SEARCH UNIQUE PATTERN LENGTH
10:30	. SEARCH TRACK LENGTH
11:28	. SEARCH TRACK LENGTH MINIMUM
12:F0	. BYTES TO VERIFY AFTER WRITE
13:00	. MANUAL OVERRIDE END OF TRACK
14:00	. HI-RES SCREEN
15:00	. SYNC FROM THIS TRACK
16:05	. TIMER LOOP BEFORE SYNC (high)
17:08	. SYNC TRACK OFFSET
18:01	. ADD TO TIMER ON ERROR
19:0D	. LENGTH OF SYNC TABLE
1A---27	. SYNC TABLE
28:00	. ANALYZE/MODIFY TRACK
29:FF	. FIX INVALID DATA WITH THIS DATA BYTE
2A:01	. FIX INVALID DATA WITH THIS TIME LENGTH
2B---38	. TABLE; SEARCH FOR THIS DATA
39:00	. ADD AFTER FINDING TABLE
3A:00	. ADD AFTER FINDING TABLE (high)
3B---48	. TABLE; CHANGE TO THIS DATA
49---56	. TABLE; CHANGE TO THIS TIMING LENGTH
57---64	. TABLE; LOCATING THE START OF TRACK
65:3D	. LOGIC PERFORMED ON DATA BYTES
66:00	. VALUE AFTER LOGIC
67---6E	. LOGIC BIT PATTERNS
6F:24	. ARMWAIT1
70:FF	. ARMWAIT2
71---80	. TABLE FOR ARM MOVE
81:03	. WRITE VERIFY SEARCH START
82:06	. WRITE VERIFY SEARCH LENGTH
83:FF	. ERASE TRACK DATA VALUE
84:01	. ERASE TRACK TIMING LENGTH
85:02	. TRACK DUMP SENSITIVITY
86:01	. SOUND ROUTINES

- 0 = If error try to fix.
- 1 = Do not verify written track.
- 2 = Ignore read errors, do not verify written track.
- 4 = Do not compress track, give error "L".
(same as pressing "-")
- 8 = Do not write track if a read error occurs.
- 10 = Do not write to duplicate disk.
Analyze original disk only.

01. LEAD-IN DATA VALUE:00. (00-FF)
Instruction or data parm. Erase the duplicate track with this data value before writing the original track to duplicate disk and also use for the track lead-in. Take this "8 bit" data value, and add the length to parm 02, to make an 8, 9, 10, 11, or 12 bit long timing byte. If the value of this parm is larger than 7F (80-FF) use this data value, with parm 02. If this value equals 00 then re-use the data value found in the track, with parm 02. If this value is between 00 and 80 (01-7F), re-use both the data and timing values found in the actual track. Used to give a track a known value for lead-in.

02. LEAD-IN DATA EXTRA BITS:02. (00-04)
Data parm. Only active if parm 01 is larger than 7F (80-FF) or equal to 00. When writing track, add this amount to the length of the data byte (parm 01)

- 0 = data byte + 0 = 8 bit data byte (normal data byte)
- 1 = data byte + 1 = 9 bit data byte (normal 3.2 DOS timing byte)
- 2 = data byte + 2 = 10 bit data byte (normal 3.3 DOS timing byte)
- 3 = data byte + 3 = 11 bit data byte
- 4 = data byte + 4 = 12 bit data byte

Used to give the lead-in byte (parm 01) a known length.

03. MAXIMUM WRITE ERRORS ALLOWED:05. (00-FF)
Instruction parm. Number of attempts allowed to re-write a track to the duplicate disk, until it verifies. Not active if parm 00=1, 2 or 10. Used to help prevent error code "W".

04. MAXIMUM READ ERRORS ALLOWED:03. (00-FF)
Instruction parm. Number of attempts allowed to re-read a track from the original disk until it verifies. Not active if parm 00=2. Used to help prevent error code "R".

05. TIMING GAP CLEAN ROUTINE:18. (00-10)
Instruction parm. If this parm value is greater than 0, the processing code "G" will be activated. Add each routine you want and input the sum.

- 0 = Copy timing bytes accurately.
- 1 = Change all timing bits to 1.
- 2 = Change all timing bits to 2.
- 3 = Change all timing bits to 3.
- 4 = Change all timing bits to average.
- 8 = Set length of first byte in each gap to 10.
- 10 = Set any 8 bit data byte found between two 9 bit timing bytes to a 9 bit timing byte.

06. TRACK GAP ROUTINE:00. (00-01)
Instruction parm. While searching for the start track gap, the timing bit lengths in the gaps are considered to be:
0 = Anything longer than 8 bits.
1 = All the same length, longer than 8 bits.
Used to possibly find a different track start.

07. CUT GAP POSITION:00. (00-02)
Instruction parm. After finding the largest gap (with parm 06), where should the the track start/end be?
0 = Before the gap.
1 = Middle of the gap.
2 = After the gap.
Used for calculating different possible track starts.

08,09. ADD GAP:FF. (00-FF)
Support parm. Number of bytes to add to the start of the track, found after parm 07, to define a new start track. Parm 08=low, 09=high:
0 = Add nothing.
1-7F = Add value to start.
80-FF = Subtract value from start.
Use for calculating different track starts.

0A. MAXIMUM TRACK LENGTH:1A. (01-FF)
Support parm. Give the high byte maximum length of the track. You may need to change this to 1C on disks with long tracks. Usually the maximum track length is between 19-1C. Used as the highest location to search for the track length. If too low, an error "R" will occur.

0B. MINIMUM TRACK LENGTH:13. (01-FF)
Support parm. Give the high byte minimum length of the track. Usually the minimum track length would be between 13-16. Used as the lowest location to search for the track length. If too high, an error "R" will occur.

0C. KNOWN DATA LENGTH (high byte):11. (00-FF)
Support parm.
The least amount of data assumed to be used from the largest gap. Used for finding valid data.

0D. COMPRESS START:08. (00-FF)
Support parm. When deleting timing bits, add this amount to the start of the track. Used to preserve the timing bits on the first few bytes in the track, preventing an error "W".

0E. COMPRESS OFFSET:70. (00-FF)
Support parm.
When deleting timing bits, add this amount to the last byte modified to search for the next byte to be modified. Used to create a more even compressed track.

0F. SEARCH UNIQUE PATTERN LENGTH:10. (01-FF)
Support parm. When searching the track for a unique data pattern, use this length. Used to help prevent 'R' errors.

10. SEARCH TRACK LENGTH:30. (01-FF)

Support parm. The amount of bytes that are searched for locating the track length. Used with parm 11 to help prevent 'R' errors.

11. SEARCH TRACK LENGTH MINIMUM:28. (01-FF)

Support parm.
From the number of bytes in parm 10, this is the minimum amount of bytes that have to match. This parm is only valid if less than parm 10. Used to help prevent 'R' errors.

12. BYTES TO VERIFY AFTER WRITE:FO. (01-FF)

Support parm. The number of bytes to verify to ensure that the track was correctly written. Used to prevent error "W".

13. MANUAL OVERRIDE END OF TRACK:00. (00-02)

Instruction parm. After EDD defines the end of a track, you may re-define it.

- 0 = Ignore this parm.
- 1 = Yes.
- 2 = Yes, override any read errors.

Movement keys:

- Arrow keys = horizontal.
- "p" and ";" for vertical.
- "L" = jump to start of track buffer.

Used for manually defining your own track end/start and/or looking through the track.

14. HI-RES SCREEN:00. (00-02)

Instruction parm. The hi-resolution screen contains the track's timing bits. Do you want the hi-resolution screen turned on during the read processing?

- 0 = no.
- 1 = yes

Used to display the timing bits, for a visual look, while duplicating disks.

15. SYNC FROM THIS TRACK:00 (00-8C)

Support parm. This value equals the number of quarter tracks to move away from track zero, before looking for the SYNC TABLE (parms 1A-27). Example: Lets say you wanted to sync from track 10. Since it takes four quarter tracks to move a distance equal to one whole track, you would have to multiply 10 by four, to find out how many quarter tracks you need to move from track 00. If you change this value, you will almost certainly have to change the SYNC TABLE (parms 1A-27). Used to synchronize off a different track, if needed.

16. TIMER LOOP BEFORE SYNC:05. (0-15)
(high byte)

Support parm. When syncing tracks, use this timer value to ensure there is enough time for the sync routine to work. Used to prevent error "S".

17. SYNC TRACK OFFSET:08. (00-FF)

Support parm. Add this amount to the SYNC TIMER before the write, to offset the sync track slightly. Used to make the sync tracks more precise.

18. ADD TO TIMER ON ERROR:01. (01-FF)

Support parm. If the sync timer is not long enough for the sync routine, add this amount and try again. Used to prevent error "S".

19. LENGTH OF SYNC TABLE:0D. (00-0D)

Support parm. Number of bytes of data to compare when looking for the SYNC TABLE (parms 1A-27).

1A-27. SYNC TABLE:

Data parm. Table of bytes to compare for the synchronize routine to continue.

D5,AA,96,7F,7F,AA,AA,AA,AA,7F,7F,7F,7F,7F
This has been preset for most 3.3 disks track 00, sector 00. If you are duplicating a 3.2 disk, change the "96" (parm 1C) to value "B5".
7F = wildcard.

These bytes must be on the track specified in parm 15. Used to prevent an error flashing "S".

28. ANALYZE/MODIFY TRACK:00. (00-7F)

Instruction parm. If this parm value is greater than "0", the processing code "A" will be activated.

- 00 = Do not analyze/modify track.
- 01 = Use logic search (parms 65,66,67-6E) to replace raw data values to parm 29.
- 02 = Use logic search (parms 65,66,67-6E) to replace timing bit lengths to parm 2A.
- 04 = Use logic search (parms 65,66,67-6E) to replace timing bit lengths to "0" after track start is found.
- 08 = Make sure that the high bits are set on all raw data.
- 10 = Search the raw data for parms 2B-38 data pattern, add parm 39 and 3A, replace with the new data pattern (parms 3B-48).
- 20 = Similar to using value 10. Instead of changing data values, change the timing values to time length table (parms 49-56).
- 40 = Use data pattern (instead of timing gaps) for locating track start (parms 57-64).

Each bit position activates different routines. To use a combination of routines, add the values of the each routine you want to use, then input the sum. These processes (if selected) are done in this order: 20,10,02,01,08,40 then 04. Used to modify the raw disk data and maybe to calculate a different track start.

29. FIX INVALID DATA WITH THIS DATA BYTE:FF. (00-FF)

Data parm. Usually, only a valid disk byte value should be used. Valid only if parm 28 has the "1" bit on. Used to prevent error "R".

2A. FIX INVALID DATA WITH THIS TIME LENGTH:01. (00-04)

Data parm.
Valid only if parm 28 has the "2" bit on. Used to by pass some protections.

2B-38. TABLE; SEARCH FOR THIS DATA:

Data parm. Use this pattern when fixing track.

D5,AA,96,7F,7F,7F,7F,7F,7F,7F,7F,7F,7F,7F,7F

This table has been preset for finding normal DOS 3.3 address fields. (for normal DOS 3.2 change parm 2D to B5).

7F = wildcard.

Valid only if parm 28 has the 10 or the 20 bit on. Used to locate certain patterns in the track.

39-3A. ADD AFTER FINDING TABLE:

Support parm.

parm 39 = low byte:00. (00-FF)

3A = high byte:00. (00-FF)

Valid only if parm 28 has the 10 or the 20 bit on. Used to change the values of certain bytes in the track.

3B-48. TABLE; CHANGE TO THIS DATA:

Data parm. Use this pattern to change the data.

7F,7F,7F,7F,7F,7F,7F,7F,7F,7F,DE,AA,EB

This table has been preset for changing epilogue fields of each sector to normal DOS 3.2 and 3.3.

7F = wildcard.

Valid only if parm 28 has the 10 bit on. Used to change certain bytes in the track.

49-56. TABLE; CHANGE TO THIS TIMING LENGTH:

Data parm. Use this pattern to change the timing bytes.

2,2,1,0,0,0,0,0,0,0,0,0,1,1,0

This table has been preset to change the first two bytes of the address field prologues to 2, epilogues to 1, and everything else to 0.

7F = wildcard.

Valid only if parm 28 has the 20 bit on. Used to change the length of certain bytes of the track.

57-64. TABLE; LOCATING THE START OF TRACK.

Data parm. The first match of raw data using this pattern is considered to be the track start.

D5,AA,7F,7F,7F,7F,7F,AA,AA,7F,7F,7F,7F,7F

Preset for finding sector zero of standard 3.2 and 3.3 DOS disks.

7F = wildcard.

Only used if parm 28 has the 40 bit on.

65. LOGIC PERFORMED ON DATA BYTES:3D. (1D,3D,5D, or DD)

Instruction parm. This tells EDD what type of logic to perform on a track. Each byte of raw data is either ORA, AND, EOR, or CMP to each byte of the LOGIC BIT PATTERNS (parms 67-6E). If the result is either equal to "00" or parm 66, then replace the data byte (if parm 28=1) to parm 29 and/or the timing byte (if parm 28=2) to parm 2A and/or the timing byte (if parm 28=4) to "00". Valid values are:

1D = ORA (or)

3D = AND (and)

5D = EOR (exclusive-or)

DD = CMP (compare)

Used only if parm 28 has the 1, 2, and/or the 4 bits on. Preset equaling "AND", to help locate invalid bytes.

66. VALUE AFTER LOGIC:00. (00-FF)

Data parm. If the result of the logic performed (using parms 28, 65, and table 67-6E) equals "00" or this value then replace either the data byte (if parm 28=1) to parm 29 or the timing byte (if parm 28=2) to parm 2A or the timing byte (if parm 28=4) to "00". Used only if parm 28 has the 1, 2, and/or the 4 bits on.

67-6E. LOGIC BIT PATTERNS:

Data parm. Use these bytes as bit patterns while logically searching the raw data bytes. Preset for locating invalid bytes containing more than two consecutive zero's in a row or with out their high bit on. If the result of a raw data byte and any of these bit pattern values equal "00" (preset parm 66 value) after logically "AND"ing (preset parm 65 value) them, the data byte is then considered to be invalid.

80,70,38,1C,0E,07,07,07

Only used if parm 28 has the 1, 2 or the 4 bit on.

6F. ARMWAIT1:24. (01-FF)

Support parm. Wait routine between all phased arm movement. Used to keep the computer from attempting to move the arm faster than the disk drive can physically move it. Used to change the speed of the arm move.

70. ARMWAIT2:FF. (01-FF)

Support parm. Wait routine used after the arm move is complete. This will give the computer enough time to let the arm come to a rest, before trying to read or write data.

71-80. TABLE FOR ARM MOVE:

Support parm. Phase table for setting the arm move. Quarter and three quarter tracks use each byte in table. whole and half track use every other byte.

1,1,1,3,3,3,3,5,5,5,5,7,7,7,7,1

Usually you wouldn't need to modify this table.

81. WRITE VERIFY SEARCH START:03. (01-06)

Support parm. EDD subtracts this amount from the original track length to start searching the duplicate disk for the difference in track lengths. Used to help prevent error "W". Used with parm 82.

82. WRITE VERIFY SEARCH LENGTH:06. (01-20)

Support parm. If the duplicate disks track length hasn't been found after this amount of bytes have been searched, a write error "W" will occur. Used with parm 81.

83. ERASE TRACK DATA VALUE:FF. (00-FF)

Data parm. When erasing tracks (mode#7), erase the track with this data value. Usually only a valid disk byte should be used. used with parm 84.

84. ERASE TRACK TIMING LENGTH:01. (00-04)

Data parm. When erasing tracks (mode#7), add this length to parm 83 to create a timing bit if necessary.

85. TRACK DUMP SENSITIVITY:02. (00-03,10)

Support/instruction parm. While dumping a track, if a byte has not be received during the strobe of;

- 0 = 25 or 31 cycles
- 1 = 26 or 32 cycles
- 2 = 27 or 33 cycles
- 3 = 28 or 34 cycles

the byte will be considered a timing byte. Drive speed can be very critical. Some disk drives can not read/write bytes longer than 10 bits:

- 00 = if longer than 10 bits, make it 10 bits.
- 10 = if longer than 11 bits, make it 11 bits.

86. SOUND ROUTINES:01. (00-01)

Instruction parm. Pressing cntrl-S from any prompt will turn this parm value to 0.

- 0 = OFF
- 1 = ON

OPTION 3: ANALYZE ORIGINAL DISK.

By measuring the ability to read a track from an original disk, a person can often tell which tracks contain valid data. Knowing this, you can then copy the correct whole, half and quarter tracks from a disk. Locating the tracks which contain valid data can also be done by numbering your disk drive as described in Appendix B.

After pressing "3" from the OPTION MENU, you are being asked for the START TRACK (the track you want to start analyzing), default 00. Next, you will be asked for the END TRACK (the last track you want to analyze), default 22. And last, the INC TRACK (the increment value or distance between the tracks to analyze), default 01. You will usually want to use either .25 (press .2) or .5 here. Insert your ORIGINAL disk, press any key to continue.

EDD analyzes one track at a time, automatically moving to the next track until all tracks specified have been analyzed. Pressing the SPACE BAR will single step EDD manually through each track. Pressing any other key will disable this manual mode and continue analyzing as normal.

Displayed in INVERSE video, the only processing code for this option is:

A = ANALYZING track.

Displayed in NORMAL video, the error codes with comments and possible problems are as follows:

- . = Track appears to contain large amounts of valid data.
Track appears to have a strong signal.
- = Track appears to be only partially recorded.
Cross talk (bleed over) from an adjacent track.
Track has a weak signal.
Track contains invalid data.
- * = Track appears to contain little or no valid data.
Track is unrecorded.
Cross talk from an adjacent track.
Track has a very weak signal.
Track contains invalid data.

While using this option, the bottom of your screen will display dots "." and asterisks "*" representing one complete track analyzed:

- . = Valid data/timing gaps.
- * = Invalid data, weak signal or unrecorded sections of track.

To use this option efficiently takes practice and some experience. We suggest that you experiment on a couple of your non-protected disks first.

Sample #3.1 shows what a valid track usually looks like:

This disk, Sample #3.7, appears to be using track 0, then tracks 1.5 through F.5 spaced 1 track apart. The rest of the disk appears to be unrecorded.

This protected disk, Sample #3.8, is a little harder to decode:

```

000000000000000011111111111111112222
TRK:0123456789ABCDEF0123456789ABCDEF0123
.00(.....*.....
.25(.....*.....
.50(.....*.....
.75(.....*.....
Sample #3.8

```

It appears that tracks 0 through 11 are valid, but then the higher tracks are partially unrecorded. This disk could be using a spiral type of protection. I would probably try copying tracks 0 through tracks 11, increment 1, then tracks 12.25 through 22.25, increment 1, with mode#2.

SAMPLE for advanced users: I am using two Apple II disk drives. My first drive is a year older than my second. I initialized a disk with standard DOS on one drive then analyzed the disk on the other. This is what I get:

```

000000000000000011111111111111112222
TRK:0123456789ABCDEF0123456789ABCDEF0123
.00(.....
.25(.....
.50(.....
.75(.....
Sample #3.9

```

What do you think? It appears that my drives are not compatible. The tracking of at least one of my drives is not linear. This can present a problem when copying quarter or three quarter tracks.

OPTION 4: EXAMINE SPEED OF ORIGINAL DISK.

This option is aimed at the more advanced user.

The main purpose of this option is for you to be able set your original disk drive to the same speed that your original disk was written. If this is done, EDD can more accurately locate the timing bits hidden between the data bytes on the original disk. EDD, then, can more accurately write them to the duplicate disk. On some protected disks, especially ones that check the timing bits, or disks requiring synchronized tracks, this can be very important.

Some software companies use a very slow drive when they write their disks. When the disk is written with a slow drive, the track will contain more data bytes than a track which was written with a normal speed drive. If this disk is copied with a normal speed drive, the duplicate disk will contain fewer bytes of data than the original track. This means that the duplicate disk is missing bytes of data. To prevent this from becoming a problem, the speed of your disk drives would have to run at the same or a slower speed than the disk drive which originally wrote the disk. In this way you can be sure that the duplicate disk contains at least all of the data which the original disk contains.

On the other hand; if you are copying a disk with a slower speed disk drive than the one which wrote the original disk, the track will contain all the bytes found on the original disk, plus extra bytes of data left over from the track lead-in. Too much data is often better than not enough. Although, some copy-protections look at the tracks just to see if they are too long or too short.

As you begin to understand how the information is set up on a disk, this OPTION will make more sense to you. Some of the following information is presented to give you more knowledge of your computer and disks and may not be important as far as running EDD. For the more advanced user, the following is a basic description of how information is usually set up on a disk:

All data is written to the disk one byte at a time, as far as software is concerned.

A standard "8 bit" byte of data is written to the disk in a 32 cycle loop. Therefore, it takes 4 cycles to write a single bit.

A timing byte is a standard "8 bit" byte, with at least 1 extra bit attached. A timing byte can have 1, 2, 3, or even up to 4 extra bits attached, resulting in a timing byte a total of 9, 10, 11, or 12 bits long. The main purpose of a timing byte is to synchronize the software with the hardware so that the disk drive can read the bytes correctly.

Normal 3.2 DOS use 1 extra bit timing bytes. Thus the length of the timing bytes are 9 bits long. Normal 3.3 DOS use 2

OPTION 5: CHECKING DRIVE SPEED.

Disk drive speeds running too fast, is the most common problem when backing up disks.

This option allows you to check and adjust the speed of your disk drives.

A normal Apple drive is supposed to run at 300rpm. Over a period of time, your disk drives may gain or lose speed and may need to be re-adjusted.

After pressing 5 from the OPTION MENU, you are being asked which disk drive you want to check. Press "D" for the duplicate drive (the default) or "0" for the original.

WARNING: Since checking drive speeds erases track 00 on the test disk, use a BLANK disk.

Insert a BLANK disk into the drive you are testing.

Press any key to start checking the speed of the drive.

Look at the scale in the center of the display:

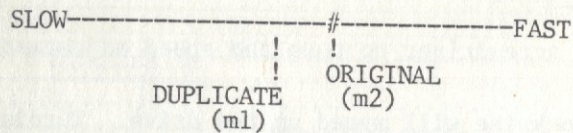

Figure #5.1

Figure #5.1, shows where the pointer should be pointing for normal operation of all disk drives. The ORIGINAL mark (m2) is approximately 300rpm (standard speed).

Through our experience, we have found that many protected disks could be copied with little or no trouble if we adjusted the speed of the original disk drive to the ORIGINAL mark (m2) and then slowed the speed of the duplicate disk drive down to the DUPLICATE mark (m1).

Although we leave our disk drives running at these speeds most of the time, we suggest that after you are done backing up your disks, you should adjust the speed of both drives back to the ORIGINAL mark (m2) for normal operation.

ADJUSTING DRIVE SPEED:

WARNING: adjusting your disk drive speed may void your warranty... If your disk drive needs to be adjusted; and you do not want to adjust it yourself, bring it to an authorized Apple dealer.

First, decide which disk drive needs to be adjusted.

Turn the computer OFF.

Remove the disk drive cover (see Appendix A).

Turn the computer ON, running EDD. Go to the OPTION MENU.

Find the speed adjustment screw towards the right-rear of the disk drive (Figure #5.2):

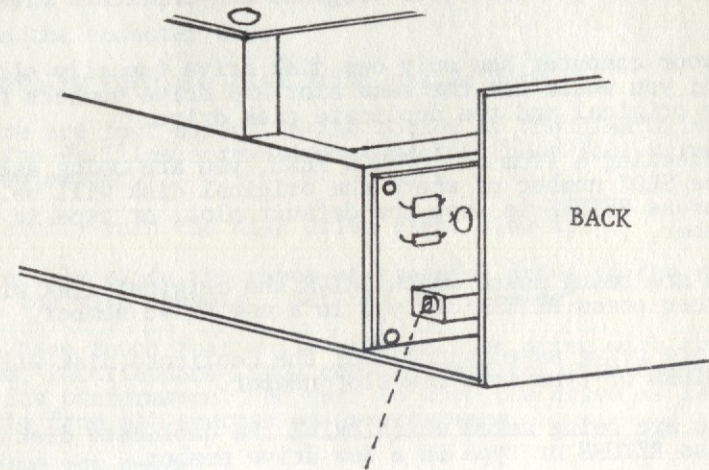

Figure #5.2

Follow these steps for each drive:

If your drive is running slow, carefully turn the speed adjustment screw clockwise to speed up the drive.

If your drive is running fast, carefully turn the speed adjustment screw counter-clockwise to slow the drive down.

Adjust the drive speed either to the ORIGINAL mark (m2) or to the DUPLICATE mark (m1). For normal operation, adjust all disk drive speeds to the ORIGINAL mark.

When done; turn the computer OFF and replace the top cover back on the disk drive (see Appendix A).

OPTION 6: CHANGE SLOTS/DRIVES.

The values shown under the error/processing status line shows you where EDD assumes the original disk and the duplicate disk:

ORIGINAL:S=6,D=2 DUPLICATE:S=6,D=1

This option lets you to change the slot and drive assignment of EDD to where you want your original and duplicate disks to be.

*** If your computer has only one disk drive (usually slot 6, drive 1); you would use the same slot and drive numbers for both the original and the duplicate disk drive.

After selecting 6 from the OPTION MENU, you are being asked to enter the SLOT number of where the original disk will be. Either press RETURN to keep the default slot, or type in a new slot number.

You then are being asked which DRIVE the original disk will be. Either press RETURN or type in a new drive number.

Now you are being asked which SLOT the duplicate disk will be. Press RETURN or type in a new slot number.

Last, you are being asked which DRIVE the duplicate disk will be. Press RETURN or type in a new drive number.

OPTION 7: CLEAR ERROR/PROCESS CODES.

After you process a disk, the top of the screen, the error/processing code status, will contain left over error/processing codes. This option will clear (erase) these codes, and then return to the OPTION MENU.

OPTION 8: QUIT, BOOT DISK.

Pressing 8 from the OPTION MENU will quit EDD.

APPENDIX A:

Instructions for removing and replacing disk drive covers.

WARNING: Removing the cover from your disk drive may VOID your warranty.

You will need a medium sized Phillips screwdriver.

REMOVING THE COVER:

1. Turn the computer OFF.
2. Carefully turn the disk drive upside down.
3. There are four screws on the bottom of the disk drive. Using the Phillips screwdriver, unscrew these four screws. Set them aside.
4. Carefully turn the disk drive right side up.
5. Carefully slide the cover of the disk drive to the rear and off of the main chassis. Set the cover aside.

*** We have found that while using a disk drive with the cover removed, interference (from computer/monitor) can drastically alter its performance. Be sure to move the drive as far as possible from all sources of interference.

REPLACING THE COVER:

1. Turn the computer OFF.
2. Carefully slide the cover back onto the drive being careful not to damage components.
3. Carefully turn the disk drive upside down.
4. Line up the four screw holes and reinstall the four screws on the bottom of the disk drive.
5. Carefully turn the disk drive back, right side up.

APPENDIX B:

NUMBERING THE TRACKS ON YOUR DISK DRIVE.

There are two main reasons you should number the tracks on your disk drive.

1. To see which tracks need to be copied from an original disk.
2. To see where an error may have occurred on a duplicate disk.

This modification is for the more advanced user.

It is important to know which tracks your protected program is accessing so you will know which tracks to copy using EDD. Also, if you have marked the arm move gear, you can watch and see whether the program is reading only the whole tracks or if it is looking in between for information on the half and/or quarter track positions.

NUMBERING TRACKS ON DISK DRIVE:

WARNING: Numbering tracks on your disk drive may VOID your warranty.

Turn the computer OFF.

You will need: a Phillips screwdriver and a fine tip marker pen.

Since you usually run programs in drive #1, this is the drive you may prefer to number.

Follow instructions in Appendix A to remove the disk drive cover.

Turn the computer ON, booting EDD.

Using OPTION 6, CHANGE SLOTS/DRIVES, type in the slot/drive number of the drive you are going to mark.

From the OPTION MENU, press 4, EXAMINE SPEED OF ORIGINAL DISK, keeping "00" as the track to analyze. When EDD asks you insert an original disk, insert any write-protected disk (such as your EDD disk).

Locate the arm move gear (figure B-1).

Pressing RETURN moves the arm to the track specified, track "00".

Using a fine tipped marker pen. Draw an arrow on the frame of the disk drive pointing to the arm move gear (figure B-2).

Draw a mark on the arm move gear lined up with the arrow on the frame and write a small "0" next to the mark indicating track zero (figure B-3).

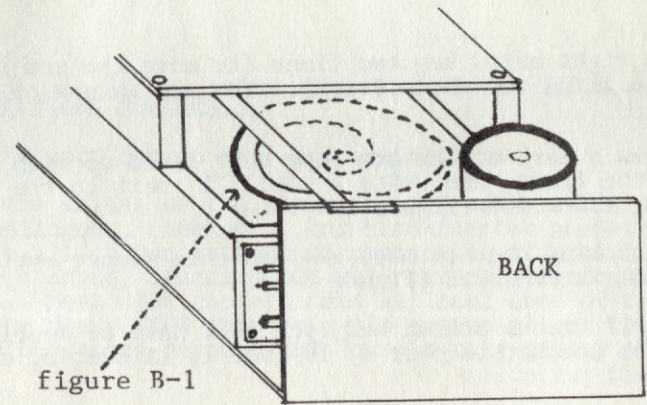

figure B-1

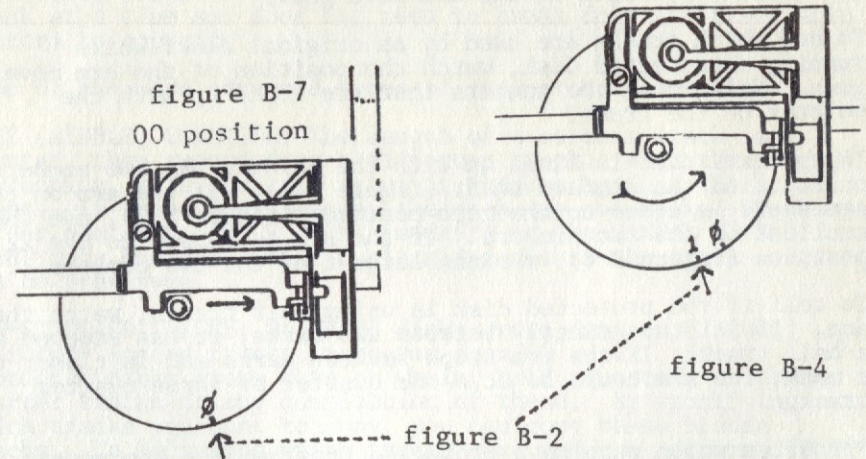

figure B-3

figure B-7
00 position

figure B-4

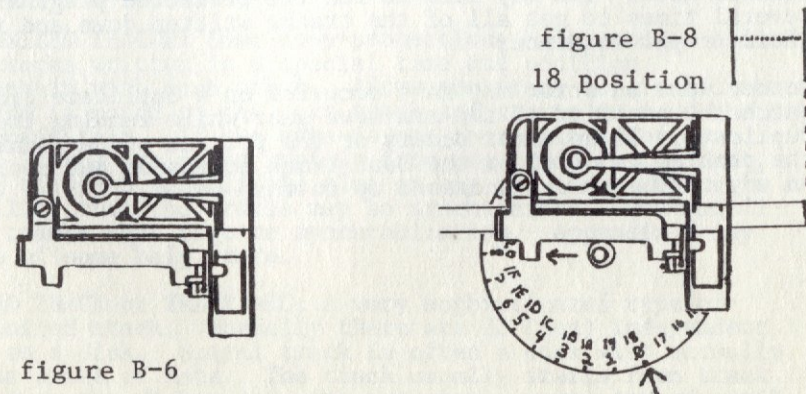

figure B-6

figure B-5

figure B-8
18 position

Press the right arrow key two times (to move the arm two half tracks equalling one whole track). The arm is now on track one.

Again, draw a mark on the arm move gear lined up with the arrow on the frame, and write a small "1" next to the mark indicating track one (figure B-4).

Continue marking the arm move gear in this manner until 23 (hex) tracks are marked (figure B-5).

*** After 17 tracks are marked, you will have to double up the rest of the tracks: 18 over 0, 19 over 1, 1A over 2, etc... (figure B-5)

USING NUMBERED TRACKS:

The top cover of the drive must be off (see Appendix A) so you can see the position of the arm move gear.

To see which tracks are used by an original disk: While running a protected disk, watch the position of the arm move gear. Write down the numbers that are lined up with the pointer on the frame.

If the mark that is lined up with the pointer has two numbers on it, find the arm/arm shaft (figure B-6). If the arm on the arm shaft is close to the zero position (figure B-7), use the smallest of the two numbers. If the arm is closer to the 22 position (figure B-8), use the largest of the two numbers.

To tell if the protected disk is using half tracks, watch the arm. If it stops exactly between two marks, it has stopped at a half track. If the arm stops between marks and is closer to a mark, the arm could be at a one quarter or three quarter track.

*** Often while running a protected program, the arm moves from one track to the next faster than you can write the track numbers down. You may need to run the protected program several times to get all of the tracks written down and in their proper sequence.

To see were an error may have occurred on a duplicate disk: Watch the position of the arm move gear while running the duplicate. If an error occurs or the program stops running, the problem is often on the last track accessed, but could be on any of the tracks accessed up to that point.

APPENDIX C:

COPY-PROTECTIONS SCHEMES...

Some of the more common copy-protections are:

Changing the values of the timing bytes, address fields, data fields, epilogues, checksums, and track/sector numbers on tracks are all common methods of protecting disks. If any of these are changed, standard DOS will not be able to access this disk. Most disk copiers need at least some of this data to copy the disk. EDD automatically copies all of these types of copy-protections because EDD doesn't rely on any of this data.

Changing the number and/or positioning of the sectors on a track will stop standard DOS and several disk copiers from making copies of these disks. EDD automatically copies disks with these kinds of copy-protections. EDD copies a whole track at a time and does not need to break down the track into sectors to copy it.

Some of the more advanced types of copy-protections are:

BYTE (NIBBLE) COUNTING: The length of a certain track is counted, then recorded on a different track. When the program is running, this recorded value is checked against the actual count. If these don't match, the disk may not work. By using either the AUTO NIBBLE COUNT (mode#3) or the MANUAL NIBBLE COUNT mode (mode#4) while duplicating disks, the track lengths can be preserved.

NON-STANDARD TRACKS: Standard disks write data on 22 (hex) uniformly spaced tracks, numbered from 00 to 22. Some protected disks store data on whole, half, quarter, or three quarter tracks or any combination of these. By specifying which tracks you want to copy, you can copy these hidden tracks. To help find which tracks are used, we recommend that you use OPTION 3, ANALYZE ORIGINAL DISK, or make the drive modification as described in Appendix B.

SYNCHRONIZED TRACKS: Some copy-protections have some or all of their tracks written in a special time and position relationship with each other. After one track is a read, the drive arm is moved to the next track and starts to read the data immediately. If the data is not there, an error can occur. If the arm moves rapidly from one track to the next, seeming to spend very little time on any one track, there is a possibility that the tracks may be synchronized. Use mode#2 on the tracks that require synchronization. Appendix B may also be of some help, here.

SPIRALED TRACK or TRACK ARC: A very sophisticated type of synchronized track. Normally there are 22 (hex) independent tracks on a disk. Spiral track is often a disk with actually only one track of data. The track usually starts from track zero and as the disk spins, the arm slowly moves inward until the read is complete. Some disks only have certain sections

that are spiralled. This type of protection can be thought of as being a disk, spiralled like the groove of a phonograph record. These are very difficult to copy, but we have been able to duplicate many disks with this type of protection. Often if you copy track numbers 00, then tracks 00.25 through 22.25, increment 1, using the SYNC TRACKS mode (mode#2), you may be able to copy each whole/half track. Drive speed is often critical.

DATA BYTES WITH EXTRA TIME BITS: On more advanced copy-protections some of the normal gaps and data bytes may have a few extra bits added to them. Then, when the program is ran, these bytes would be checked to see if they still contain the extra bits with which they were written. If the disk has been copied with other copy programs, these bytes will have been written to the duplicate disk as normal bytes without the extra bits added. EDD automatically takes care of this protection if your disk drives are running close to their proper speeds. Be sure that you don't get error codes "C" or "L" while duplicating disks which would erase timing bits if this type of protection is being used.

Some copy-protections use several of the above techniques and can be very difficult to copy.

APPENDIX D:

HEX/DECIMAL CONVERSION...

"Hex" is short for "hexadecimal".

Hex is a computer numbering system. Decimal is a human numbering system.

The difference between decimal and hex is that decimal counts from "0" to "15", and hex counts from "00" to "0F". A dollar sign (\$) is often used to define a hex number.

The following is a conversion chart for converting decimal numbers to hex and vice-versa.

An example: A disk drive with 22 (hex) tracks, actually has 34 tracks.

DECIMAL	\$HEX	DECIMAL	\$HEX	DECIMAL	\$HEX	DECIMAL	\$HEX
0	= 00	32	= 20	64	= 40	96	= 60
1	= 01	33	= 21	65	= 41	97	= 61
2	= 02	(34	= 22)	66	= 42	98	= 62
3	= 03	35	= 23	67	= 43	99	= 63
4	= 04	36	= 24	68	= 44	100	= 64
5	= 05	37	= 25	69	= 45	101	= 65
6	= 06	38	= 26	70	= 46	102	= 66
7	= 07	39	= 27	71	= 47	103	= 67
8	= 08	40	= 28	72	= 48	104	= 68
9	= 09	41	= 29	73	= 49	105	= 69
10	= 0A	42	= 2A	74	= 4A	106	= 6A
11	= 0B	43	= 2B	75	= 4B	107	= 6B
12	= 0C	44	= 2C	76	= 4C	108	= 6C
13	= 0D	45	= 2D	77	= 4D	109	= 6D
14	= 0E	46	= 2E	78	= 4E	110	= 6E
15	= 0F	47	= 2F	79	= 4F	111	= 6F
16	= 10	48	= 30	80	= 50	112	= 70
17	= 11	49	= 31	81	= 51	113	= 71
18	= 12	50	= 32	82	= 52	114	= 72
19	= 13	51	= 33	83	= 53	115	= 73
20	= 14	52	= 34	84	= 54	116	= 74
21	= 15	53	= 35	85	= 55	117	= 75
22	= 16	54	= 36	86	= 56	118	= 76
23	= 17	55	= 37	87	= 57	119	= 77
24	= 18	56	= 38	88	= 58	120	= 78
25	= 19	57	= 39	89	= 59	121	= 79
26	= 1A	58	= 3A	90	= 5A	122	= 7A
27	= 1B	59	= 3B	91	= 5B	123	= 7B
28	= 1C	60	= 3C	92	= 5C	124	= 7C
29	= 1D	61	= 3D	93	= 5D	125	= 7D
30	= 1E	62	= 3E	94	= 5E	126	= 7E
31	= 1F	63	= 3F	95	= 5F	127	= 7F

APPENDIX E:

COMMON ERRORS...

EDD WILL NOT BOOT:

If the "APPLE II" message at the top of your display does not go away: Make sure your EDD disk is write-protected. Try booting the back side of your EDD disk.

If EDD starts to boot, then fails, displaying a screen full of dots: Open, then close the disk drive door (to ensure the disk is centered) while the drive is running. Try booting the back side of your EDD disk.

Note: EDD boots on half tracks. Some (very few) apple compatible disk drives can not access half tracks.

EDD APPEARS NOT TO BE WORKING:

The disk drives will not turn on... EDD will not work with some peripherals. Also be sure you are using your original EDD disk.

While trying to duplicate a disk; the wrong disk drives go on..., the slots/drives need to be changed. See OPTION 6 for details on changing the slots/drives.

While attempting to duplicate a disk, the message "WRITE-PROTECT ORIGINAL DISK" is displayed. Be sure the original disk is write-protected (the notch is covered) and inserted in the original drive, and the duplicate disk is in the duplicate drive. If the message continues to be displayed, this almost always means that the write-protect switch located inside the disk drive is out of adjustment. You might try copying from drive 1 to drive 2 (see OPTION 6).

If you have changed parameters, you may have changed a parameter value out of the valid range... See OPTION 2 for valid parameter ranges. You may need to reset the parameters back to their default (OPTION 2, cntrl-R) or reboot EDD.

A flashing "S" appears in the error status display, and the program appears to have stopped: You are in the sync tracks mode#2. The SYNC TABLE (parms 1A-27) is not matching the disk. Press ESC. Be sure that you have first copied track 00 (or the track specified in parm 15) before you attempt to synchronize the tracks (mode#2). If you did copy the track specified in parm 15 first, then you need to modify the SYNC TABLE (parms 1A-27), see TRICKS OF THE TRADE.

EDD APPEARS TO WORK, BUT A DUPLICATED DISK MADE WITH EDD DOES NOT:

Be sure that you are using your original EDD disk, and not a copy.

Check the current EDD PROGRAM LIST to see if the program you

are trying to copy is on it. If so, follow the instructions for that program.

Drive speeds running too FAST is the most common problem with copying disks... Users are often contacting us, telling us that they can't copy certain disks that should be "easy" to copy. After we tell them to slow their disk drives down, they often tell us, most of their copying problem are solved.

Read Appendix C.

Read TRICKS OF THE TRADE.

If you made the copy from drive #2 to drive #1, try copying from drive #1 to drive #2.

Drives might be going very fast or slow. See OPTION 4 and 5.

Try using only one drive. Your drives may not be very compatible.

Program may be using non standard track to store data (half, quarter, or three quarter tracks). See OPTION 3, Appendix B, and OPTION 1.

Maybe you need to copy track 23 (one more track than standard).

Try using a different process mode. See OPTION 1.

Parameters may need to be changed. Check the current parameter list. See OPTION 2 and TRICKS OF THE TRADE for some help.

APPENDIX F:

GENERAL INFORMATION.

While using EDD, a write-protect sticker must be on your original disks. If none is present, an error message will be displayed. This precaution will prevent you from accidentally erasing any information on your original disks.

While processing, the duplicate (blank) disk must not have a write-protect sticker on it or an error message will be displayed.

An Apple disk drive can not erase a disk that has a write-protect sticker on it.

If an original disk comes write-protected, be sure to put a write-protect sticker on the duplicate disk BEFORE you try to boot it... Many protections will erase themselves if they can.

When you are finished backing up your disks, remember to use OPTION 5 to re-adjust your disk drive speeds back to their standard speed for normal operation.

We have found that some peripherals (especially monitors) cause interference. This can make even unprotected disks hard to copy. Move your disk drives away from all possible sources of interference; for both, copying disks and normal operation.

EDD has been preset to copy from drive #2 to drive #1 (use OPTION 6 to change). We feel that the drive that boots the disk (drive #1) should be the one which wrote it. This is especially important when copying 1/4 and 3/4 tracks. Also it is easier to boot the duplicate disk to see if it works.

The slower the duplicate drive runs, the longer the written track will be, and the more data there will be on each track. The faster the duplicate drive runs, the shorter the written track will be, and less data there will be on each track.

When backing up disks with 2 disk drives, try to copy from the faster disk drive to the slower disk drive. It is usually better to write too much data than not enough.

TRICKS OF THE TRADE:

If you are backing up Apple III software, always use a synchronize tracks mode; either mode#2, #5, or #6. It appears that almost all Apple III software is using at least the synchronize track type of protection.

While duplicating disks, always put the original disk in the faster disk drive and the duplicate disk in the slower disk drive. Make sure that neither of your disk drives are running faster than 300rpm (see OPTION 5).

If the original disk comes write-protected, always write-protect the duplicate disk before you boot it. Some copy-protected disks try to erase themselves if they can.

If you want EDD to just examine the original disk without writing to the duplicate; change parm 00=10.

If you know that EDD will easily copy a certain disk, you can speed things up by changing parm 00=2.

If you know that a protection is NOT checking timing bit lengths, and you are sure the tracks gaps are 10 bits (3.3 DOS), changing parm 5=0 will subtract over 20 seconds of copy time.

If a protection is checking timing bits, be sure that EDD doesn't compress the track. Change parm 00=4, or use mode#4.

If the TRACK END/START does not appear to be right, you can switch in a powerful routine that might make the difference; parm 07=1. You can MANUALLY OVERRIDE END OF TRACK with parm 13=1 or 2 (see OPTION 2, parm 13, for movement keys). If you know what the track start looks like, change parm 28=40 then type it into parms 57-64 (TABLE; LOCATING THE START OF TRACK).

If the track you are reading is mostly erased and gives read errors but has a sector or two of valid data, you might decrease parm 0C=3. Or if the data on the track looks mostly the same and gives read errors, you might increase parm 0C=15. You might also try to fix the track by turning all the invalid bytes to sync bytes; change parm 28=1, 2 OR 3. This could take EDD awhile to duplicate a disk, but it can be effective.

If you get tired of putting write-protect stickers on your original disks, try folding a business card in half (long ways), covering the notch in the disk. Slide both, the card and the disk into the disk drive, leaving the end of the card extending out of the drive. The disk is now temporarily write-protected.

SYNCHRONIZING TRACKS:

To synchronize tracks accurately, it is very important that both drives are running close to the same speed, and the drives are running close to the speed at which the original disk was made.

Before synchronizing tracks, be sure to copy the SYNC FROM THIS TRACK (parm 15), first (usually track 00), so that the duplicate disk has a track to synchronize from.

While you are synchronizing tracks, you may see a flashing "S" in the error status. If it doesn't go away, you need to modify the SYNC TABLE (parms 1A-27). The bytes in this table aren't in the SYNC FROM THIS TRACK parm (parm 15).

Here is one way of finding bytes to put into the SYNC TABLE (parms 1A-27):

1. Change parm: 13=1 (MANUAL OVERRIDE END OF TRACK). Attempt to duplicate the disk starting with the track you are synchronizing from, parm 15 (usually track 00).
2. After the read; when the computer stops, move around (see OPTION 2, parm 13, for the movement keys) in the track. Search for several bytes of data in a row that appear unique. Input them into the SYNC TABLE (parms 1A-27). Change parm 19 to the amount of bytes you found. Now EDD can find the bytes in the track from the SYNC TABLE.

If you know that certain tracks on a disk need synchronizing; and a synchronized copy of the disk doesn't work, you may need to tighten up EDD's synchronize routine to obtain a more accurate synchronized tracks. Change parm 13=1 (see OPTION 2) and dump the track that you think needs synchronizing off of the original disk into memory, using mode#2. Go to the start of the buffer, and look at the first part of the track for a pattern of bytes that you will remember. Dump the same track from the duplicate disk using mode#2. Search the front of the buffer for the same pattern... You will probably be able to calculate how many bytes the synchronize routine was off. Experiment with parm 17 (SYNC TRACK OFFSET), until the front buffer for both disks looks the same. Do this for each track that needs to be synchronized.

QUARTER/THREE QUARTER TRACKS:

We find that if only one disk drive, usually the boot drive, is used while copying quarter or three quarter tracks, the copy seems to be more accurate. To keep EDD from modifying the copy, you may find that parm 00=1 does the trick.

GENERAL RECOMMENDED READING:

Beneath Apple DOS
Quality Software
6660 Reseda Blvd., Suite 105
Reseda, CA 91335
(213) 344-6599

Hardcore magazine
P.O. Box 44549
Tacoma, WA 98444

**ESSENTIAL
DATA
DUPLICATOR III**

© Copyright 1984 Utilico Microware

90534